

(19)



(11) EP 1 698 550 B1

(12)

EUROPEAN PATENT SPECIFICATION

(45) Date of publication and mention
of the grant of the patent:
23.04.2008 Bulletin 2008/17

(51) Int Cl.:
B62M 25/04 (2006.01)

(21) Application number: 06003395.8

(22) Date of filing: 20.02.2006

(54) **Bicycle shifter**

Gangschalter für ein Fahrrad

Dispositif de changement de vitesses pour bicyclette

(84) Designated Contracting States:
DE FR NL

(30) Priority: 03.03.2005 US 906730

(43) Date of publication of application:
06.09.2006 Bulletin 2006/36

(60) Divisional application:
07013014.1 / 1 840 024

(73) Proprietor: SRAM Corporation
Chicago,
Illinois 60622 (US)

(72) Inventors:
• Jordan, Brian
Chicago
Illinois 60618 (US)

- Wesling, Kevin
Lombard
Illinois 60148 (US)
- Shlpman, Christopher
Chicago
Illinois 60640 (US)

(74) Representative: Thum, Bernhard
Wuesthoff & Wuesthoff
Patent- und Rechtsanwälte
Schweigerstrasse 2
81541 München (DE)

(56) References cited:

EP-A- 0 601 211	EP-A- 1 440 878
EP-A- 1 502 847	DE-A1- 3 136 922
US-A- 5 241 878	US-A- 5 479 776
US-A1- 2002 104 401	US-A1- 2002 124 679

EP 1 698 550 B1

Note: Within nine months from the publication of the mention of the grant of the European patent, any person may give notice to the European Patent Office of opposition to the European patent granted. Notice of opposition shall be filed in a written reasoned statement. It shall not be deemed to have been filed until the opposition fee has been paid. (Art. 99(1) European Patent Convention).

Description

Background of the Invention and prior art

[0001] The present invention relates to bicycle shifters, and more particularly, to a bicycle shifter having a single control lever movable in one direction for pulling and releasing a control cable.

[0002] Conventional bicycle shifters have been designed to include separate control levers, one for pulling, another for releasing the control cable. Disadvantages of a two-lever shifter include added weight and the discomfort of repeatedly maneuvering the hand and fingers between the two levers. Bicycle shifters have also been designed to include a single lever operable in two directions, one to pull, the other to release the control cable. Although acceptable for some applications, discomfort and loss of control may result when shifting, as the rider maneuvers his hand and fingers to alternate sides of such a lever.

[0003] The prior art document US 2002/0124679 A1 discloses a bicycle shifter according to the preamble part of claim 1. It includes a control lever which can be pivoted into a shifting direction in order to perform a shift movement in one single cable pull direction.

Summary of the Invention

[0004] The present invention provides a bicycle shifter having a single control member movable in a shift direction to both pull and release a control cable connected to a gear change mechanism. The bicycle shifter includes a housing mountable to a handlebar of the bicycle, the housing enclosing a takeup member movable to pull and release the control cable in cable-pull and cable-release directions. Typically, the takeup member is biased in the cable-release direction by tension in the control cable, but may also be biased by a takeup member return spring, or the like. A holding mechanism retains the takeup member in a selected gear position, while a drive mechanism is operable to disengage the holding member in response to actuation of the control member, allowing the takeup member to move. To shift gears, the rider moves the control member in the same shift direction for a first shift movement to move the takeup member in the cable-release direction, or for a second shift movement, to move the takeup member in the cable-pull direction. Each first shift movement corresponds to a single gear change while the second shift movement corresponds to one or more gear changes. Further, the second shift movement of the control member is greater than the first shift movement. The control member is biased toward a rest position.

[0005] In one embodiment of the present invention, the takeup member is rotatable about an axis to wind and unwind the control cable thereon in the cable-pull and cable-release directions. The control member is preferably a control lever rotatably mounted to a shaft located

in the housing. The shifter further includes a ratchet wheel having preferably a plurality of unevenly spaced teeth about its periphery, the ratchet wheel being rotatable with the takeup member, while the holding mechanism includes a holding pawl engageable with the ratchet wheel teeth to retain the takeup member in a selected gear position. The holding pawl has a body and a nose extending from the body, the nose biased to engage the teeth of the ratchet wheel.

[0006] The drive mechanism includes a drive pawl rotatably mounted to the control lever, while the shifter includes a declutching element for disengaging the drive pawl from the ratchet wheel. The drive pawl has a body, a nose extending from the body, and a tail. The nose of the drive pawl is biased by a spring to engage the ratchet wheel teeth, and is engageable with the nose of the holding pawl to release the holding pawl from the ratchet wheel teeth. The tail of the drive pawl is engageable with the declutching element, preferably a declutching wall of the housing, to rotate the drive pawl and disengage the nose of the drive pawl from the ratchet wheel teeth.

[0007] Before actuation, the control lever is in a rest position, the tail of the drive pawl rests against the declutching pawl, the nose of the driver pawl is disengaged from the ratchet wheel teeth. Further, the nose of the holding pawl is engaged with a corresponding first tooth of the ratchet wheel to retain the takeup member in a selected gear position.

[0008] To perform a cable-release operation, the control lever is actuated in the shift direction, rotating the control lever about its shaft, and causing the drive pawl to pivot about its own axis to move the nose of the drive pawl toward the ratchet wheel teeth. As the control lever is further rotated, the drive pawl engages the holding pawl nose to release it from engagement with the first tooth on the ratchet wheel. In alternative embodiments, intermediate elements may transmit motion between the drive pawl and holding pawl. Once disengaged, the takeup member and ratchet wheel are free to rotate in the cable-release direction until the drive pawl nose engages the same first tooth of the ratchet wheel. The engagement of the drive pawl nose with the just-released first tooth of the ratchet wheel, provides both audible and tactile feedback to the rider, signaling when to stop moving the control lever in the shift direction and releasing the lever to effect a cable-release operation. As the control lever is released, now rotating toward its rest position, the tail of the drive pawl bears against the declutching wall, rotating the drive pawl to disengage the drive pawl nose from the ratchet wheel teeth. When the drive pawl nose disengages from the first tooth of the ratchet wheel, the takeup member and ratchet wheel rotate in the cable-release direction, under the tensile force of the control cable, until the nose of the holding pawl engages the adjoining second tooth, resulting in a gear shift by one gear increment in the cable-release direction. At the end of the cable-release operation, the drive pawl returns to its rest position against the declutching wall, to position the control

lever in its rest position.

[0009] To perform a cable-pull operation, instead of releasing the control lever upon disengagement of the holding pawl from the ratchet wheel during a cable-release operation, the lever is further rotated in the shift direction. Further rotation of the control lever causing the drive pawl to drive the takeup member and the ratchet wheel in the cable-pull direction, while the holding pawl free-clutches, the holding pawl nose freely sliding along the teeth of the ratchet wheel. The rider may rotate the control lever in the shift direction until the holding pawl nose engages a ratchet wheel tooth corresponding to a single, or multiple, gear shift increments in the cable-pull direction. Once a desired gear position is reached, the control lever is released and it rotates toward its rest position, now causing the drive pawl nose to free-clutch over the ratchet wheel teeth, while the holding pawl retains the takeup member in the selected gear position.

[0010] These and other features and advantages of the invention will be more fully understood from the following description of various embodiments of the invention, taken together with the accompanying drawings.

Brief Description of the Drawings

[0011] In the drawings:

FIG. 1 is a partial cross-sectional view of a bicycle shifter according to one embodiment of the present invention;

FIG. 2 is an enlarged partial cross-sectional view of the bicycle shifter to FIG. 1;

FIGS. 3a-3f are cross-sectional views of a holding mechanism and a drive mechanism at different stages of a cable-release operation; and

FIGS. 4a-4h are cross-sectional views of the holding mechanism and the drive mechanism at different stages of a cable-pull operation.

Detailed Description

[0012] FIGS. 1-4 illustrate a bicycle shifter 10 according to one embodiment of the present invention. The bicycle shifter 10 pulls or releases a control cable 11 connected to gear change mechanism (not shown) to shift between various gear positions. The gear change mechanism may be a derailleur, or other external or internal gear change devices. The bicycle shifter 10 is mounted to a handlebar 12 by a clamp 14 and a bolt 16. The bicycle shifter 10 shown is a road shifter for use on a road bike. However, similar shifters may be adapted for use on other types of bicycles, including mountain bikes. In this embodiment, the bicycle shifter 10 generally includes a housing 18, a control member 20, a takeup member 22, a holding mechanism 24 and a drive mechanism 26. In

this embodiment, the shifter 10 is integrated with a brake lever 28. The brake lever 28 pivots about a brake pivot 30, pulling a brake cable (not shown) to slow the bicycle. Alternatively, the brake lever 28 may be formed separately from the shifter 10.

[0013] In this embodiment, the housing 18 is mounted to the handlebar 12 and a mounting shaft 32 extends through the housing 18. The control member 20, in this embodiment a control lever 20, includes a first portion 34 and a second portion 36, the first portion 34 rotatably mounted to the shaft 32. The control lever 20 is biased toward a rest position by a preloaded control lever return spring 38. A first leg 40 of the control lever return spring 38 is received in an opening 42 in the housing 18, and a second leg 44 of the control lever return spring 38 is received in an opening 46 in the control lever 20. The second portion 36 of control lever 20, in addition to rotating about shaft 32 along with first portion 34, also rotates about a perpendicular lever shaft 48 mounted to the first portion 34 of the control lever 20. The second portion 36 of the control lever 20 is biased by a preloaded return spring 50 mounted coaxially with the lever shaft 48. A first leg of the return spring 50 is received in an opening in the second portion 36 of the control lever 20, and a second leg of the return spring 50 is supported by the first portion 34 of the control lever 20. In this embodiment, the control lever 20 includes two portions 34, 36 to allow the second portion 36 of the control lever 20 to move with the brake lever 28 when the brake lever 28 is actuated. In other embodiments, the control lever 20 may be formed as one piece.

[0014] The takeup member 22, in this embodiment a spool, is rotatably mounted on the shaft 32. The takeup member 22 includes a groove 52 along its periphery, for receiving the control cable 11. The takeup member 22 is biased in the cable-release direction by tension in the control cable 11 and, preferably, by a takeup member return spring 54. The takeup member return spring 54 is disposed between the takeup member 22 and the housing 18. The return spring 54 includes a first leg 56 received in an opening 58 in the takeup member 22, and a second leg 60 received in an opening 62 in the housing 18.

The shifter 10 includes a ratchet wheel 64 having preferably a plurality of unevenly spaced teeth 66 about its periphery, while the holding mechanism 24 includes a holding pawl 68 engageable with the teeth 66 to prevent unwinding of the takeup member 22. The ratchet wheel 64 is rotatably mounted to the shaft 32 and rotates with the takeup member 22. The ratchet wheel teeth 66 correspond to gear positions of the gear change mechanism. Alternatively, the ratchet wheel 64 and the takeup member 22 may be formed as one piece. The holding pawl 68 is rotatable about a holding pawl pivot 70 fixed to the housing 18, and is axially positioned by a retaining ring 72. The holding pawl 68 includes a body 74, and a nose 76 extending from the body 74. The holding pawl nose 76 is biased to engage the ratchet wheel teeth 66 by a

preloaded holding pawl spring 78, coaxially mounted to the holding pawl pivot 70. A first leg 80 of the holding pawl spring 78 is received in an opening in the housing 18, and a second leg 86 is supported by the holding pawl 68.

[0015] The drive mechanism 26 includes a drive pawl 84 rotatably mounted about a drive pawl pivot 90 fixed to the control lever 20. The drive pawl 84 is axially positioned by a retaining ring 92. The drive pawl 84 includes a body 94, a nose 96 extending from the body 94, and a tail 98. A drive pawl spring 100 biases the drive pawl nose 96 toward the ratchet wheel teeth 66. The tail 98 of the drive pawl 84 rests against a declutching element 88, in this embodiment, a declutching wall 88 of the housing 18, when the control lever 20 is in its rest position.

[0016] To shift the gear change mechanism, the control lever 20 is rotated in the shift direction for a first shift movement to release the control cable 11, and in the same direction for a second shift movement to pull the control cable 11, the second shift movement being greater than the first shift movement. Looking to FIGS. 3a-3f, a cable-release operation is described. Before the control lever 20 is actuated, the tail 98 of the drive pawl 84 rests against the declutching wall 88, positioning the control lever 20 in its rest position (FIG. 3a). Further, the takeup member 22 and the ratchet wheel 64 are retained in a selected gear position by the holding pawl 68, shown engaging a corresponding first tooth 102.

[0017] Looking to FIG. 3b, as the control lever 20 is actuated by the rider, the lever 20 rotates about the shaft 32, moving the drive pawl 84 away from the declutching wall 88, and pivoting the drive pawl nose 96 toward the ratchet wheel teeth 66. Looking to FIG. 3c, as the lever 20 is further rotated, the drive pawl nose 96 engages the holding pawl nose 76, causing the holding pawl 68 to release the first tooth 102 of the ratchet wheel 64. Once released, the ratchet wheel 64 rotates about the shaft 32 in the cable-release direction, until the first tooth 102 engages the drive pawl nose 96. This action provides both audible and tactile feedback to the rider, signaling the rider to release the control lever 20, if a cable-release operation is desired.

[0018] Looking to FIG. 3d, as the control lever 20 is released, allowing it to pivot towards its rest position, the ratchet wheel 64 rotates in the cable-release direction. Further, the holding pawl nose 76 moves toward engagement with a recess 104 associated with an adjoining second tooth 106 of the ratchet wheel 64, and the drive pawl tail 98 moves toward engagement with the declutching wall 88. As the control lever 20 rotates further toward its rest position, the drive pawl nose 96 pivots further away from the ratchet wheel teeth 66, due to the torque created as the drive pawl tail 98 bears against the declutching wall 88 (FIG. 3e). When the drive pawl 84 disengages from the ratchet wheel teeth 66, the ratchet wheel 64 rotates in the cable-release direction under the force of the control cable 11 and the takeup member return spring 54, until the holding pawl nose 76 engages the second

adjoining ratchet wheel tooth 106, resulting in a gear shift, by one gear increment, in the cable-release direction. At the end of the cable-release operation, the drive pawl 84 moves back to its rest position against the declutching wall 88 (FIG. 3f), positioning the control lever 20 in its rest position.

[0019] Looking to FIGS. 4a-4h, a cable-pull operation is described. Before the control lever 20 is actuated, the drive pawl tail 98 rests against the declutching wall 88, positioning the control lever 20 in its rest position (FIG. 4a). So positioned, the ratchet wheel 64 is retained in a selected gear position with the holding pawl 68 engaging the first ratchet wheel tooth 102. As the control lever 20 is actuated by the rider in the shift direction, the drive pawl 84 moves away from the declutching wall 88, positioning the drive pawl nose 96 toward the ratchet wheel teeth 66 (FIG. 4b).

[0020] Looking to FIG. 4c, as the control lever 20 is further rotated, the drive pawl nose 96 engages the holding pawl nose 76, driving the holding pawl nose 76 out of engagement with the first ratchet wheel tooth 102. Once released, the ratchet wheel 64 rotates in the cable-release direction until the first tooth 102 engages the drive pawl nose 96. As the control lever 20 is further rotated in the shift direction, the drive pawl 84 drives the ratchet wheel 64 in cable-pull direction, as the holding pawl 68 free-clutches, the holding pawl nose 76 freely sliding along the ratchet wheel teeth 66 (FIG. 4d).

[0021] Looking to FIG. 4e, as the control lever 20 is further rotated, the drive pawl 84 further rotates the ratchet wheel 64 in the cable-pull direction until the holding pawl 68 engages a next third tooth 110 on the ratchet wheel 64, resulting in a single gear shift in the cable-pull direction. The rider, of course, is not limited to single gear shift increments in the cable-pull direction. The rider may readily shift multiple gear increments in the cable-pull direction by simply continuing to move the control lever in the shift direction, until the desired gear position is reached. Audible and tactile feedback is provided to the rider as each gear shift increment is passed.

[0022] Looking to FIG. 4f, after the desired gear position is reached, the rider releases the control lever 20 causing the control lever 20 and the drive pawl 84 to rotate toward their rest positions under the force of the control lever return spring 38. As the control lever 20 further rotates toward its rest position, the drive pawl tail 98 bears against the declutching wall 88, creating a torque that rotates the drive pawl 84 away from the ratchet wheel teeth 66 (FIG. 4g). Looking to FIG. 4h, the drive pawl 84 is in its rest position against the declutching wall 88, with the drive pawl nose 96 disengaged from the ratchet wheel 64.

[0023] While this invention has been described by reference one or more preferred embodiments, it should be understood that numerous changes could be made within the scope of the inventive concepts as defined in the appended claims. Accordingly, it is intended that the invention not be limited to the disclosed embodiments, but

that it have the full scope permitted by the language of the following claims.

Claims

1. A bicycle shifter (10) for pulling and releasing a control cable (11) connected to a gear change mechanism, the bicycle shifter (10) comprising:

a housing (18) mountable to a handlebar (12);
a takeup member (22) movable for pulling the control cable (11) in a cable-pull direction and releasing the control cable (11) in a cable-release direction,

wherein the takeup member (22) is biased in the cable-release direction;

a control member (20) movable in a shift direction from a rest position for shift movements and biased toward said rest position; and

a holding mechanism (24) for retaining the takeup member (22) in a selected gear position;

characterized in that

the bicycle shifter further comprises
a drive mechanism (26) operable for releasing the holding mechanism (24) from the takeup member (22) and for moving the takeup member (22) in response to actuation of the control member (20), wherein said control member (20) is movable in said shift direction from the rest position

- for a first shift movement to permit motion of the takeup member (22) in the cable-release direction, wherein the first shift movement corresponds to a single gear change, and

- for a second shift movement to move the takeup member (22) in the cable-pull direction, wherein the second shift movement corresponds to a plurality of gear changes and wherein the second shift movement of the control member (20) is greater than said first shift movement.

2. The bicycle shifter (10) according to claim 1, wherein the takeup member (22) is rotatable about an axis (32) for winding and unwinding to the control cable (11) thereon.

3. The bicycle shifter (10) according to claim 1 or 2, further comprising a ratchet wheel (64) rotatable with the takeup member (22) and having a plurality of teeth (66), the holding mechanism (24) including a holding pawl (68) biased to engage the ratchet wheel teeth (66) to retain the takeup member (22) in a selected gear position.

4. The bicycle shifter (10) according to claim 3, wherein

the holding pawl (68) is rotatably mounted to the housing (18).

5. The bicycle shifter (10) according to claim 3 or 4, wherein the holding pawl (68) is biased to engage the ratchet wheel (64) by a spring (78).

6. The bicycle shifter (10) according to one of claims 3 to 5, wherein the drive mechanism (26) includes a drive pawl (84) rotatably mounted to the control member (20) and biased to engage the ratchet wheel teeth (66), the drive pawl (84) operable for releasing the holding pawl (68) from the ratchet wheel teeth (66) and for rotating the takeup member (22) in response to actuation of the control member (20).

7. The bicycle shifter (10) according to claim 6, further comprising a declutching element (88) for disengaging the drive pawl (84) from the ratchet wheel (64).

8. The bicycle shifter (10) according to claim 7, wherein the declutching element (88) is a declutching wall of the housing (18).

9. The bicycle shifter according to one of claims 6 to 8, wherein the drive pawl (84) is biased by a spring (100).

10. The bicycle shifter (10) according to claim 7 or 8, wherein the drive pawl (84) includes a body (94) pivotally attached to the control member (20), a nose (96) engageable with the ratchet wheel teeth (66), and a tail (98) engageable with the declutching element (88); and the holding pawl (68) includes a body (74) pivotally attached to the housing (18) and a nose (76) engageable with the ratchet wheel teeth (66).

11. The bicycle shifter (10) according to claim 10, wherein after the first shift movement, the tail (98) of the drive pawl (84) abuts against the declutching element (88) to disengage the nose (96) of the drive pawl (84) from the ratchet wheel teeth (66).

12. The bicycle shifter (10) according to claim 10 or 11, wherein the tail (98) of the drive pawl (84) abuts against the declutching element (88) during motion of the control lever (20) toward its rest position.

13. The bicycle shifter (10) according to one of claims 10 to 12, wherein the drive pawl (84) is operable such that the drive pawl nose (96) disengages the holding pawl nose (76) from the ratchet wheel teeth (66) to permit rotation of the takeup member (22) in response to actuation of the control member (20).

14. The bicycle shifter (10) according to claim 2 and one of the preceding claims, wherein the control mem-

ber (20) is a pivotable control lever biased toward the rest position by a return spring (50).

Patentansprüche

1. Fahrradschaltvorrichtung (10) zum Ziehen und Freigeben eines Steuerkabels (11), das mit einem Gangwechselmechanismus gekoppelt ist, wobei die Fahrradschaltvorrichtung (10) umfasst:

ein Gehäuse (18), das an einer Lenksstange (12) anbringbar ist;

ein Aufnahmeelement (22), das zum Ziehen an dem Steuerkabel (11) in einer Kabel-Zugrichtung und zum Freigeben des Steuerkabels (11) in einer Kabel-Freigaberichtung bewegbar ist, wobei das Aufnahmeelement (22) in die Kabel-Freigaberichtung vorgespannt ist;

ein Steuerelement (20), das in einer Schallrichtung aus einer Ruheposition für Schaltbewegungen bewegbar ist und auf die Ruheposition hin vorgespannt ist; und

einen Haltemechanismus (24) zum Halten des Aufnahmeelements (22) in einer ausgewählten Gangposition;

dadurch gekennzeichnet, dass

die Fahrradschaltvorrichtung ferner umfasst:

einen Getriebemechanismus (26), der zum Lösen des Haltemechanismus (24) von dem Aufnahmeelement (22) und zum Bewegen des Aufnahmeelements (22) in Antwort auf eine Betätigung des Steuerelements (20) betätigbar ist, wobei das Steuerelement (20) in der Schallrichtung aus der Ruheposition

- für eine erste Schaltbewegung zum Zulassen einer Bewegung des Aufnahmeelements (22) in der Kabel-Freigaberichtung bewegbar ist, wobei die erste Schaltbewegung einem einzelnen Gangwechsel entspricht, und

- für eine zweite Schaltbewegung zum Bewegen des Aufnahmeelements (22) in der Kabel-Zugrichtung bewegbar ist, wobei die zweite Schaltbewegung einer Mehrzahl von Gangwechseln entspricht und wobei die zweite Schaltbewegung des Steuerelements (20) größer ist als die erste Schaltbewegung.

2. Fahrradschaltvorrichtung (10) nach Anspruch 1, wobei das Aufnahmeelement (22) um eine Achse (32) zum Aufwickeln und Abwickeln des Steuerkabels (11) auf diesem drehbar ist.

3. Fahrradschaltvorrichtung (10) nach Anspruch 1 oder 2, ferner umfassend ein Rastrad (64), das mit dem Aufnahmeelement (22) drehbar ist und eine Mehrzahl von Zähnen (66) aufweist, wobei der Haltemechanismus (24) eine Halteklau (68) aufweist, die vorgespannt ist, um mit den Rastradzähnen (66) in Eingriff zu gelangen, um das Aufnahmeelement (22) in einer ausgewählten Gangposition zu halten.

4. Fahrradschaltvorrichtung (10) nach Anspruch 3, wobei die Halteklau (68) drehbar an dem Gehäuse (18) angebracht ist.

5. Fahrradschaltvorrichtung (10) nach Anspruch 3 oder 4, wobei die Halteklau (68) durch eine Feder (78) vorgespannt ist, um mit dem Rastrad (64) in Eingriff zu gelangen.

6. Fahrradschaltvorrichtung (10) nach einem der Ansprüche 3 bis 5, wobei der Getriebemechanismus (26) eine Getriebeklau (84) umfasst, die drehbar an dem Steuerelement (20) angebracht und vorgespannt ist, um mit den Rastradzähnen (66) in Eingriff zu gelangen, wobei die Antriebsklau (84) zum Lösen der Halteklau (68) von den Rastradzähnen (66) und zum Drehen des Aufnahmeelements (22) in Antwort auf eine Betätigung des Steuerelements (20) betätigbar ist.

7. Fahrradschaltvorrichtung (10) nach Anspruch 6, ferner umfassend ein Löseelement (88) zum Außereingriffbringen der Getriebeklau (84) von dem Rastrad (64).

8. Fahrradschaltvorrichtung (10) nach Anspruch 7, wobei das Löseelement (88) eine Lösewand des Gehäuses (18) ist.

9. Fahrradschaltvorrichtung nach einem der Ansprüche 6 bis 8, wobei die Getriebeklau (84) durch eine Feder (100) vorgespannt ist.

10. Fahrradschaltvorrichtung (10) nach Anspruch 7 oder 8, wobei die Antriebsklau (84) einen schwenkbar an dem Steuerelement (20) angebrachten Körper (94), eine mit den Rastradzähnen (66) in Eingriff bringbare Nase (96) und einen mit dem Löseelement (88) in Eingriff bringbaren Ausläufer (98) aufweist; und wobei die Halteklau (68) einen Körper (74) umfasst, der schwenkbar an dem Gehäuse (18) angebracht ist, und eine Nase (76) umfasst, die mit den Rastradzähnen (66) in Eingriff bringbar ist.

11. Fahrradschaltvorrichtung (10) nach Anspruch 10, wobei nach der ersten Schaltbewegung der Ausläufer (98) der Getriebeklau (84) mit dem Löseelement (88) in Anlage gelangt, um die Nase (96) der Getriebeklau (84) von den Rastradzähnen (66) außer Ein-

griff zu bringen.

12. Fahrradschaltvorrichtung (10) nach Anspruch 10 oder 11, wobei der Ausläufer (98) der Getriebeklaue (84) während einer Bewegung des Steuerhebels (20) auf seine Ruhestellung zu in Anlage mit dem Löseelement (88) gelangt.

13. Fahrradschaltvorrichtung (10) nach einem der Ansprüche 10 bis 12, wobei die Getriebeklaue (84) derart betätigbar ist, dass die Getriebeklauennase (96) die Halteklauennase (76) außer Eingriff von der Rastradverzahnung (66) bringt, um eine Drehung des Aufnahmeelements (22) in Antwort auf eine Betätigung des Steuerelements (20) zuzulassen.

14. Fahrradschaltvorrichtung (10) nach Anspruch 2 und einem der vorangehenden Ansprüche, wobei das Steuerelement (20) ein schwenkbarer Steuerhebel ist, der in die Ruheposition über eine Rückstellfeder (50) vorgespannt ist.

Revendications

1. Manette de dérailleur de bicyclette (10) pour tirer et libérer un câble de commande (11) connecté à un mécanisme de changement de vitesse, la manette de dérailleur de bicyclette (10) comprenant :

un logement (18) pouvant être monté sur un guidon (12) ;

un élément de palier tendeur (22) mobile pour tirer le câble de commande (11) dans une direction de traction du câble et libérer le câble de commande (11) dans une direction de libération du câble, dans laquelle l'élément de palier tendeur (22) est poussé dans la direction de libération du câble ;

un élément de commande (20) mobile dans une direction de passage de rapport d'une position de repos pour des mouvements de passage de rapport et poussé vers ladite position de repos ; et

un mécanisme de maintien (24) pour maintenir l'élément de palier tendeur (22) dans une position de dérailleur sélectionnée ;

caractérisée en ce que

la manette de dérailleur de bicyclette comprend en outre

un mécanisme d'entraînement (26) utilisable pour libérer le mécanisme de maintien (24) de l'élément de palier tendeur (22) et pour déplacer l'élément de commande (20),

dans laquelle ledit élément de commande (20) est mobile dans ladite direction de passage de rapport

à partir de la position de repos

- pour un premier mouvement de passage de rapport pour permettre le mouvement de l'élément de palier tendeur (22) dans la direction de libération du câble, dans laquelle le premier mouvement de passage de rapport correspond à un changement de rapport unique, et

- pour un deuxième mouvement de passage de rapport pour déplacer l'élément de palier tendeur (22) dans la direction de traction du câble, dans laquelle le deuxième mouvement de passage de rapport correspond à une pluralité de changements de rapport et dans laquelle le deuxième mouvement de passage de rapport de l'élément de commande (20) est plus grand que ledit premier mouvement de passage de rapport.

2. Manette de dérailleur de bicyclette (10) selon la revendication 1, dans laquelle l'élément de palier tendeur (22) est rotatif autour d'un axe (32) pour enrouler et dérouler le câble de commande (11) sur celui-ci.

3. Manette de dérailleur de bicyclette (10) selon la revendication 1 ou 2, comprenant en outre une roue à rochet (64) rotative avec l'élément de palier tendeur (22) et ayant une pluralité de dents (66), le mécanisme de maintien (24) incluant un cliquet de maintien (68) poussé pour engager les dents (66) de la roue à rochet pour maintenir l'élément de palier tendeur (22) dans une position de dérailleur sélectionnée.

4. Manette de dérailleur de bicyclette (10) selon la revendication 3, dans laquelle le cliquet de maintien (68) est monté de façon rotative sur le logement (18).

5. Manette de dérailleur de bicyclette (10) selon la revendication 3 ou 4, dans laquelle le cliquet de maintien (68) est poussé pour engager la roue à rochet (64) par un ressort (78).

6. Manette de dérailleur de bicyclette (10) selon l'une des revendications 3 à 5, dans laquelle le mécanisme d'entraînement (26) inclut un cliquet d'entraînement (84) monté de façon rotative sur l'élément de commande (20) et poussé pour engager les dents (66) de la roue à rochet, le cliquet d'entraînement (84) utilisable pour libérer le cliquet de maintien (68) des dents (66) de la roue à rochet et pour faire tourner l'élément de palier tendeur (22) en réponse à l'actionnement de l'élément de commande (20).

7. Manette de dérailleur de bicyclette (10) selon la revendication 6, comprenant en outre un élément de débrayage (88) pour désengager le cliquet d'entraînement (84) de la roue à rochet (64).

8. Manette de dérailleur de bicyclette (10) selon la revendication 7, dans laquelle l'élément de débrayage (88) est une paroi de débrayage du logement (18).
9. Manette de dérailleur de bicyclette (10) selon l'une des revendications 6 à 8, dans laquelle le cliquet d'entraînement (84) est poussé par un ressort (100). 5
10. Manette de dérailleur de bicyclette (10) selon la revendication 7 ou 8, dans laquelle le cliquet d'entraînement (84) inclut un corps (94) fixé de façon pivotante sur l'élément de commande (20), un nez (96) engageable avec les dents (66) de la roue à rochet, et une queue (98) engageable avec l'élément de débrayage (88) ; et le cliquet de maintien (68) inclut un corps (74) fixé de façon pivotante sur le logement (18) et un nez (76) engageable avec les dents (66) de la roue à rochet. 10
15
11. Manette de dérailleur de bicyclette (10) selon la revendication 10, dans laquelle après le premier mouvement de passage de rapport, la queue (98) du cliquet d'entraînement (84) vient buter contre l'élément de débrayage (88) pour désengager le nez (96) du cliquet d'entraînement (84) des dents (66) de la roue à rochet. 20
25
12. Manette de dérailleur de bicyclette (10) selon la revendication 10 ou 11, dans laquelle la queue (98) du cliquet d'entraînement (84) vient buter contre l'élément de débrayage (88) pendant le mouvement du levier de commande (20) vers sa position de repos. 30
13. Manette de dérailleur de bicyclette (10) selon l'une des revendications 10 à 12, dans laquelle le cliquet d'entraînement (84) est utilisable de telle manière que le nez (96) de cliquet d'entraînement désengage le nez (76) de cliquet de maintien des dents (66) de la roue à rochet pour permettre la rotation de l'élément de palier tendeur (22) en réponse à l'actionnement de l'élément de commande (20). 35
40
14. Manette de dérailleur de bicyclette (10) selon la revendication 2 et l'une quelconque des revendications précédentes, dans laquelle l'élément de commande (20) est un levier de commande pivotant poussé vers la position de repos par un ressort de rappel (50). 45

50

55

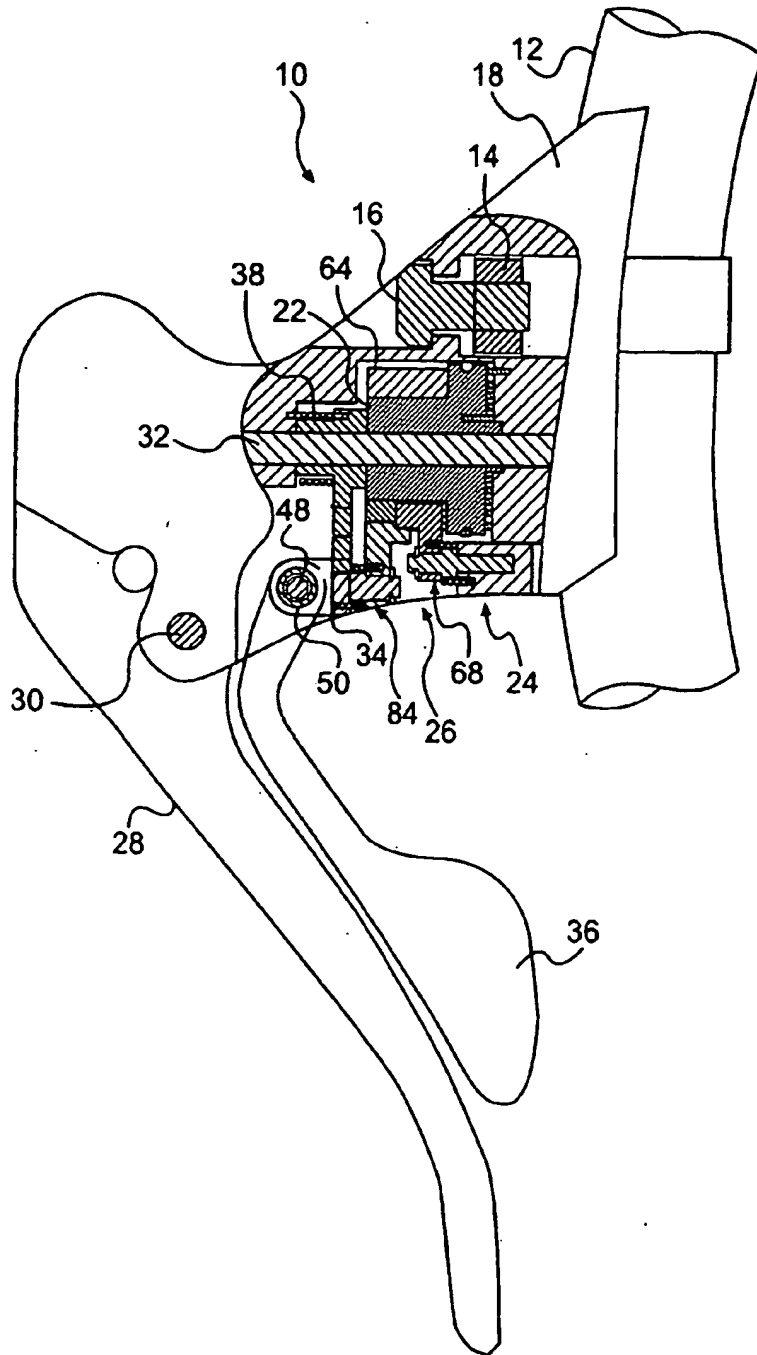

FIG. 1

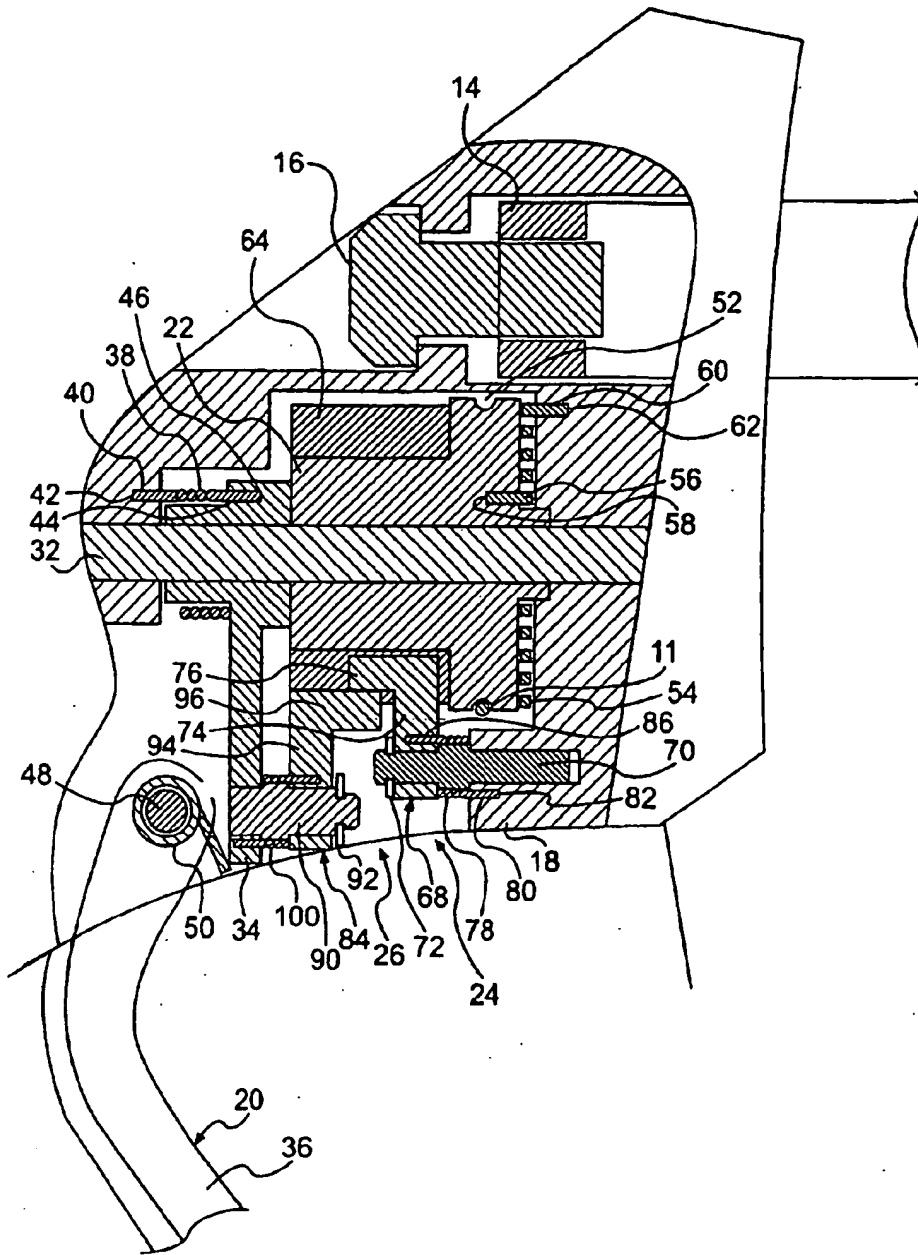

FIG. 2

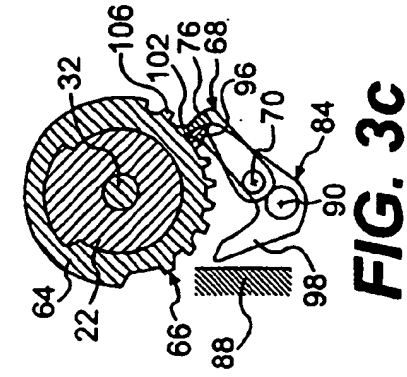

FIG. 3a

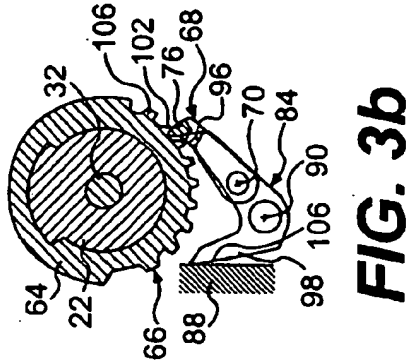

FIG. 3b

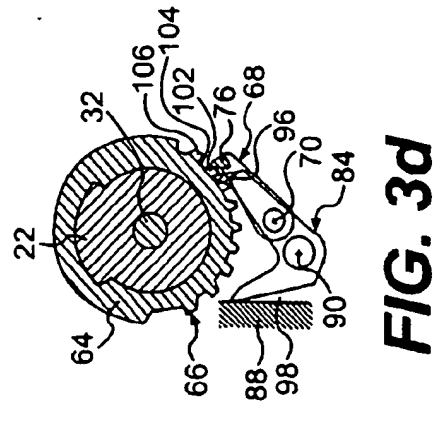

FIG. 3c

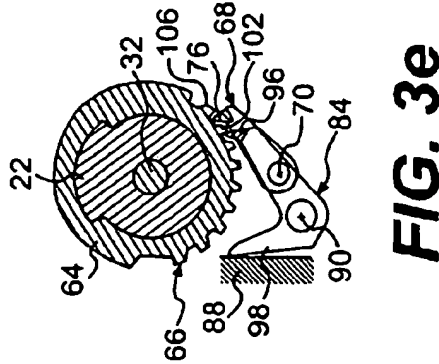

FIG. 3d

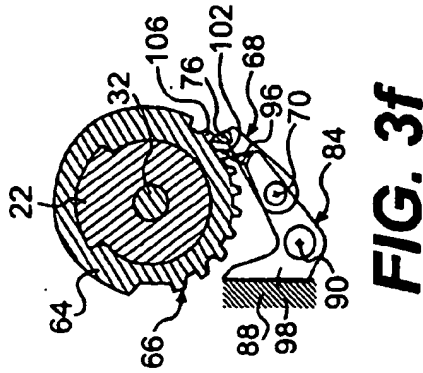

FIG. 3e

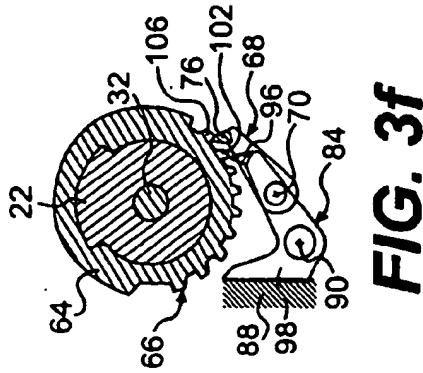

FIG. 3f

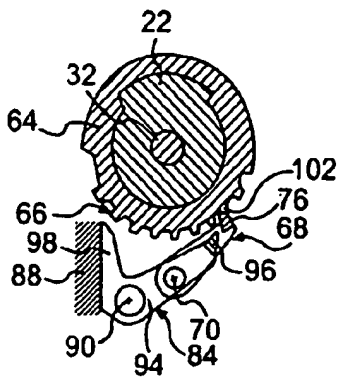

FIG. 4a

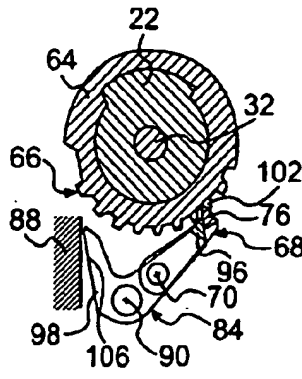

FIG. 4b

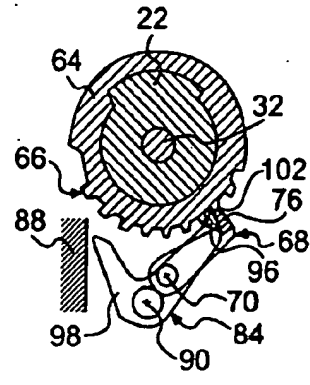

FIG. 4c

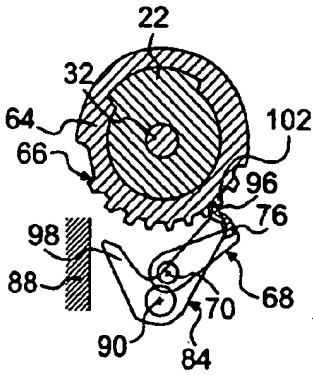

FIG. 4d

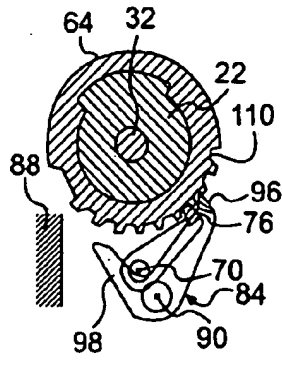

FIG. 4e

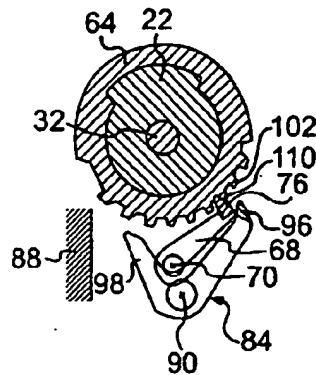

FIG. 4f

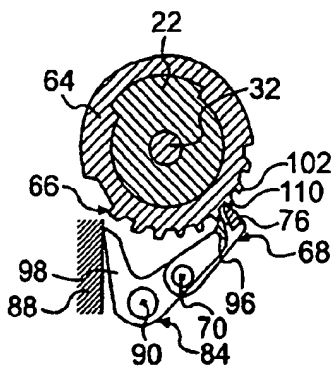

FIG. 4g

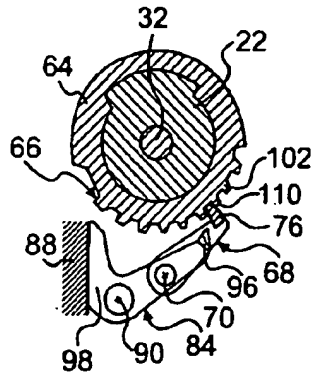

FIG. 4h

REFERENCES CITED IN THE DESCRIPTION

This list of references cited by the applicant is for the reader's convenience only. It does not form part of the European patent document. Even though great care has been taken in compiling the references, errors or omissions cannot be excluded and the EPO disclaims all liability in this regard.

Patent documents cited in the description

- US 20020124679 A1 [0003]